

### FEATURES

- Low input offset voltage: 150  $\mu\text{V}$  maximum**
- Low offset voltage drift over  $-55^\circ\text{C}$  to  $+125^\circ\text{C}$ : 1.2  $\text{pV}/^\circ\text{C}$  maximum**
- Low supply current (per amplifier): 725  $\mu\text{A}$  maximum**
- High open-loop gain: 5000  $\text{V}/\text{mV}$  minimum**
- Input bias current: 3  $\text{nA}$  maximum**
- Low noise voltage density: 11  $\text{nV}/\sqrt{\text{Hz}}$  at 1 kHz**
- Stable with large capacitive loads: 10  $\text{nF}$  typical**
- Pin-compatible to LM148, HA4741, RM4156, and LT1014, with improved performance**
- Available in die form**

### GENERAL DESCRIPTION

The OP400 is the first monolithic quad operational amplifier that features OP77-type performance. Precision performance is not sacrificed with the OP400 to obtain the space and cost savings offered by quad amplifiers.

The OP400 features an extremely low input offset voltage of less than 150  $\mu\text{V}$  with a drift of less than 1.2  $\mu\text{V}/^\circ\text{C}$ , guaranteed over the full military temperature range. Open-loop gain of the OP400 is more than 5 million into a 10  $\text{k}\Omega$  load, input bias current is less than 3  $\text{nA}$ , CMR is more than 120  $\text{dB}$ , and PSRR is less than 1.8  $\mu\text{V}/\text{V}$ . On-chip Zener zap trimming is used to achieve the low input offset voltage of the OP400 and eliminates the need for offset nulling. The OP400 conforms to the industry-standard quad pinout, which does not have null terminals.

### FUNCTIONAL BLOCK DIAGRAMS

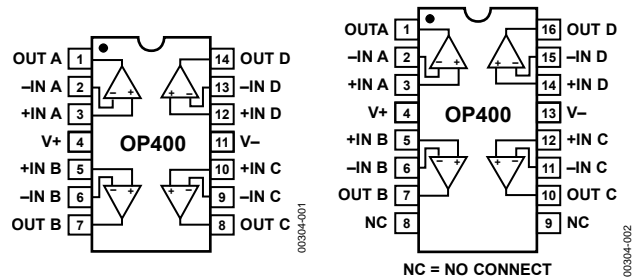

Figure 1. 14-Pin Ceramic DIP (Y-Suffix) and 14-Pin Plastic DIP (P-Suffix)

Figure 2. 16-Pin SOIC (S-Suffix)

The OP400 features low power consumption, drawing less than 725  $\mu\text{A}$  per amplifier. The total current drawn by this quad amplifier is less than that of a single OP07, yet the OP400 offers significant improvements over this industry-standard op amp. Voltage noise density of the OP400 is a low 11  $\text{nV}/\sqrt{\text{Hz}}$  at 10 Hz, half that of most competitive devices.

The OP400 is pin-compatible with the LM148, HA4741, RM4156, and LT1014 operational amplifiers and can be used to upgrade systems having these devices. The OP400 is an ideal choice for applications requiring multiple precision operational amplifiers and where low power consumption is critical.

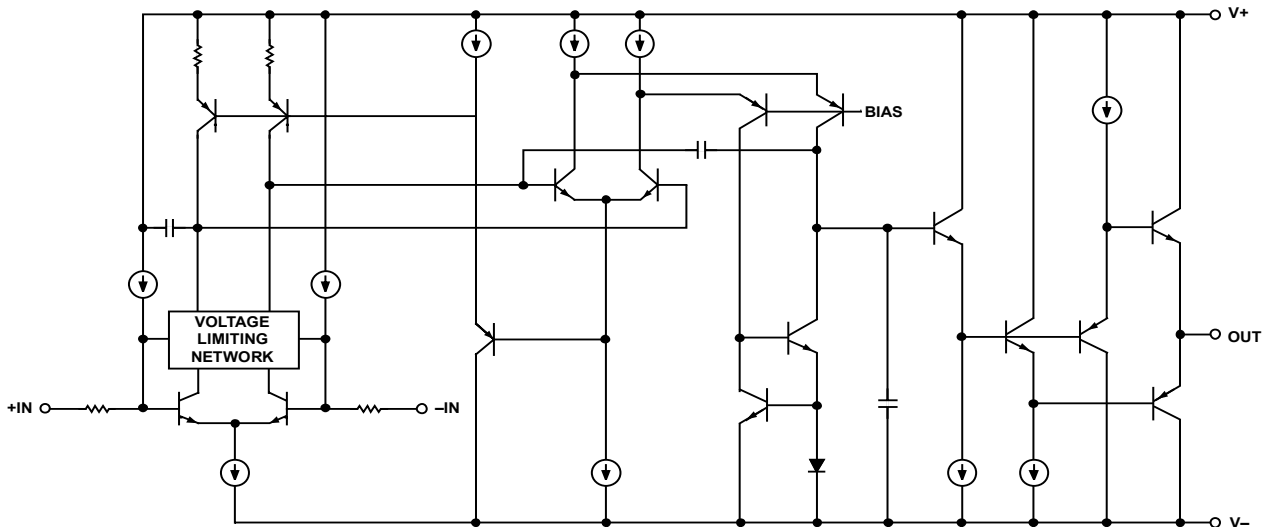

Figure 3. Simplified Schematic (One of Four Amplifiers Is Shown)

### Rev. E

Information furnished by Analog Devices is believed to be accurate and reliable. However, no responsibility is assumed by Analog Devices for its use, nor for any infringements of patents or other rights of third parties that may result from its use. Specifications subject to change without notice. No license is granted by implication or otherwise under any patent or patent rights of Analog Devices. Trademarks and registered trademarks are the property of their respective owners.

## TABLE OF CONTENTS

Features .....	1	Typical Performance Characteristics .....	6
Functional Block Diagrams.....	1	Applications.....	11
General Description .....	1	Dual Low Power Instrumentation Amplifier .....	11
Revision History .....	2	Bipolar Current Transmitter .....	12
Specifications.....	3	Differential Output Instrumentation Amplifier .....	12
Electrical Characteristics .....	3	Multiple Output Tracking Voltage Reference.....	13
Absolute Maximum Ratings.....	5	Outline Dimensions .....	14
Thermal Resistance .....	5	Ordering Guide .....	15
ESD Caution.....	5	SMD Parts and Equivalents .....	15

## REVISION HISTORY

### 1/07—Rev. D to Rev. E

Updated Format.....	Universal
Changes to Figure 1 and Figure 2 .....	1
Removed Figure 4.....	4
Changes to Table 3.....	4
Changes to Figure 16 through Figure 19, Figure 21.....	8
Changes to Figure 27 .....	9
Changes to Figure 28.....	10
Changes to Figure 33.....	13
Updated Outline Dimensions .....	14

### 3/06—Rev. C to Rev. D

Updated Format.....	Universal
Deleted Wafer Test Limits Table .....	4
New Package Drawing: R-14.....	15
Updated Outline Dimensions .....	15
Changes to Ordering Guide .....	16

### 6/03—Rev. B to Rev. C

Edits to Specifications.....	2
------------------------------	---

### 10/02—Rev. A to Rev. B

Addition of Absolute Maximum Ratings .....	5
Edits to Outline Dimensions.....	12

### 4/02—Rev. 0 to Rev. A

Edits to Features.....	1
Edits to Ordering Information .....	1
Edits to Pin Connections.....	1
Edits to General Descriptions.....	1, 2
Edits to Package Type .....	2

# SPECIFICATIONS

## ELECTRICAL CHARACTERISTICS

@  $V_S = \pm 15\text{ V}$ ,  $T_A = +25^\circ\text{C}$ , unless otherwise noted.

Table 1.

Parameter	Symbol	Conditions	OP400A/E			OP400F			OP400G/H			Unit
			Min	Typ	Max	Min	Typ	Max	Min	Typ	Max	
INPUT CHARACTERISTICS												
Input Offset Voltage	$V_{OS}$			40	150		60	230		80	300	$\mu\text{V}$
Long-Term Input Voltage Stability				0.1			0.1			0.1		$\mu\text{V}/\text{mo}$
Input Offset Current	$I_{OS}$	$V_{CM} = 0\text{ V}$		0.1	1.0		0.1	2.0		0.1	3.5	nA
Input Bias Current	$I_B$	$V_{CM} = 0\text{ V}$		0.75	3.0		0.75	6.0		0.75	7.0	nA
Input Noise Voltage	$e_{n\text{ p-p}}$	0.1 Hz to 10 Hz		0.5			0.5			0.5		$\mu\text{V p-p}$
Input Resistance	$R_{IN}$			10			10			10		M $\Omega$
Differential Mode												
Input Resistance Common Mode	$R_{INCM}$			200			200			200		G $\Omega$
Large Signal Voltage Gain	$A_{VO}$	$V_O = \pm 10\text{ V}$										
		$R_L = 10\text{ k}\Omega$	5000	12,000		3000	7000		3000	7000		V/mV
		$R_L = 2\text{ k}\Omega$	2000	3500		1500	3000		1500	3000		V/mV
Input Voltage Range <sup>1</sup>	IVR		$\pm 12$	$\pm 13$		$\pm 12$	$\pm 13$		$\pm 12$	$\pm 13$		V
Common-Mode Rejection	CMR	$V_{CM} = 12\text{ V}$	120	140		115	140		110	135		dB
Input Capacitance	$C_{IN}$			3.2			3.2			3.2		pF
OUTPUT CHARACTERISTICS												
Output Voltage Swing	$V_O$	$R_L = 10\text{ k}\Omega$	$\pm 12$	$\pm 12.6$		$\pm 12$	$\pm 12.6$		$\pm 12$	$\pm 12.6$		V
POWER SUPPLY												
Power Supply Rejection Ratio	PSRR	$V_S = 3\text{ V to }18\text{ V}$		0.1	1.8		0.1	3.2		0.2	5.6	$\mu\text{V}/\text{V}$
Supply Current per Amplifier	$I_{SY}$	No load		600	725		600	725		600	725	$\mu\text{A}$
DYNAMIC PERFORMANCE												
Slew Rate	SR		0.1	0.15		0.1	0.15		0.1	0.15		V/ $\mu\text{s}$
Gain Bandwidth Product	GBWP	$A_V = 1$		500			500			500		kHz
Channel Separation	CS	$V_O = 20\text{ V p-p}$ , $f_O = 10\text{ Hz}^2$	123	135		123	135		123	135		dB
Capacitive Load Stability		$A_V = 1$ , no oscillations		10			10			10		nF
NOISE PERFORMANCE												
Input Noise Voltage Density <sup>3</sup>	$e_n$	$f_O = 10\text{ Hz}^3$		22	36		22	36		22		nV/ $\sqrt{\text{Hz}}$
		$f_O = 1000\text{ Hz}^3$		11	18		11	18		11		nV/ $\sqrt{\text{Hz}}$
Input Noise Current	$i_{n\text{ p-p}}$	0.1 Hz to 10 Hz		15			15			15		pA p-p
Input Noise Current Density	$i_n$	$f_O = 10\text{ Hz}$		0.6			0.6			0.6		pA/ $\sqrt{\text{Hz}}$

<sup>1</sup> Guaranteed by CMR test.  
<sup>2</sup> Guaranteed but not 100% tested.  
<sup>3</sup> Sample tested.

# OP400

@  $V_s = \pm 15\text{ V}$ ,  $-55^\circ\text{C} \leq T_A \leq +125^\circ\text{C}$  for OP400A, unless otherwise noted.

**Table 2.**

Parameter	Symbol	Conditions	Min	Typ	Max	Unit
<b>INPUT CHARACTERISTICS</b>						
Input Offset Voltage	$V_{OS}$			70	270	$\mu\text{V}$
Average Input Offset Voltage Drift	$TCV_{OS}$			0.3	1.2	$\mu\text{V}/^\circ\text{C}$
Input Offset Current	$I_{OS}$	$V_{CM} = 0\text{ V}$		0.1	2.5	nA
Input Bias Current	$I_B$	$V_{CM} = 0\text{ V}$		1.3	5.0	nA
Large Signal Voltage Gain	$A_{VO}$	$V_O = \pm 10\text{ V}$ , $R_L = 10\text{ k}\Omega$ $R_L = 2\text{ k}\Omega$	3000 1000	9000 2300		V/mV
Input Voltage Range <sup>1</sup>	IVR		$\pm 12$	$\pm 12.5$		V
Common-Mode Rejection	CMR	$V_{CM} = \pm 12\text{ V}$		115	130	dB
<b>OUTPUT CHARACTERISTICS</b>						
Output Voltage Swing	$V_O$	$R_L = 10\text{ k}\Omega$	$\pm 12$	$\pm 12.4$		
<b>POWER SUPPLY</b>						
Power Supply Rejection Ratio	PSRR	$V_O = 3\text{ V to } 18\text{ V}$		0.2	3.2	$\mu\text{V}/\text{V}$
Supply Current per Amplifier	$I_{SY}$	No load		600	775	$\mu\text{A}$
<b>DYNAMIC PERFORMANCE</b>						
Capacitive Load Stability		$A_V = 1$ , no oscillations		8		nF

<sup>1</sup> Guaranteed by CMR test.

@  $V_s = \pm 15\text{ V}$ ,  $-25^\circ\text{C} \leq T_A \leq +85^\circ\text{C}$  for OP400E/E,  $0^\circ\text{C} \leq T_A \leq 70^\circ\text{C}$  for OP400G,  $-40^\circ\text{C} \leq T_A \leq +85^\circ\text{C}$  for OP400H, unless otherwise noted.

**Table 3.**

Parameter	Symbol	Conditions	OP400E			OP400F			OP400G/H			Unit
			Min	Typ	Max	Min	Typ	Max	Min	Typ	Max	
<b>INPUT CHARACTERISTICS</b>												
Input Offset Voltage	$V_{OS}$			60	220		80	350		110	400	$\mu\text{V}$
Average Input Offset Voltage Drift	$TCV_{OS}$			0.3	1.2		0.3	2.0		0.6	2.5	$\mu\text{V}/^\circ\text{C}$
Input Offset Current	$I_{OS}$	$V_{CM} = 0\text{ V}$ E, F, G grades H grade		0.1	2.5		0.1	3.5		0.2	6.0	nA
Input Bias Current	$I_B$	$V_{CM} = 0\text{ V}$ E, F, G grades H grade		0.9	5.0		0.9	10.0		1.0	12.0	nA
Large-Signal Voltage Gain	$A_{VO}$	$V_{CM} = 0\text{ V}$ $R_L = 10\text{ k}\Omega$ $R_L = 2\text{ k}\Omega$	3000 1500	10,000 2700		2000 1000	5000 2000		2000 1000	5000 2000		V/mV V/mV
Input Voltage Range <sup>1</sup>	IVR		$\pm 12$	$\pm 12.5$		$\pm 12$	$\pm 12.5$		$\pm 12$	$\pm 12.5$		V
Common-Mode Rejection	CMR	$V_{CM} = \pm 12\text{ V}$	115	135		110	135		105	130		dB
<b>OUTPUT CHARACTERISTICS</b>												
Output Voltage Swing	$V_O$	$R_L = 10\text{ k}\Omega$ $R_L = 2\text{ k}\Omega$	$\pm 12$ $\pm 11$	$\pm 12.4$ $\pm 12$		$\pm 12$ $\pm 11$	$\pm 12.4$ $\pm 12$		$\pm 12$ $\pm 11$	$\pm 12.6$ $\pm 12.2$		V V
<b>POWER SUPPLY</b>												
Power Supply Rejection Ratio	PSRR	$V_s = \pm 3\text{ V to } \pm 18\text{ V}$		0.15	3.2		0.15	5.6		0.3	10.0	$\mu\text{V}/\text{V}$
Supply Current per Amplifier	$I_{SY}$	No load		600	775		600	775		600	775	$\mu\text{A}$
<b>DYNAMIC PERFORMANCE</b>												
Capacitive Load Stability		No oscillations		10			10			10		nF

<sup>1</sup> Guaranteed by CMR test.

## ABSOLUTE MAXIMUM RATINGS

Table 4.

Parameter	Rating
Supply Voltage	±20 V
Differential Input Voltage	±30 V
Input Voltage	Supply voltage
Output Short-Circuit Duration	Continuous
Storage Temperature Range P, Y Packages	–65°C to +150°C
Lead Temperature (Soldering 60 sec)	300°C
Junction Temperature (T <sub>J</sub> ) Range	–65°C to +150°C
Operating Temperature Range	
OP400A	–55°C to +125°C
OP400E, OP400F	–25°C to +85°C
OP400G	0°C to 70°C
OP400H	–40°C to +85°C

Stresses above those listed under Absolute Maximum Ratings may cause permanent damage to the device. This is a stress rating only; functional operation of the device at these or any other conditions above those indicated in the operational section of this specification is not implied. Exposure to absolute maximum rating conditions for extended periods may affect device reliability.

Absolute maximum ratings apply to both dice and packaged parts, unless otherwise noted.

### THERMAL RESISTANCE

$\theta_{JA}$  is specified for worst-case mounting conditions, that is,  $\theta_{JA}$  is specified for device in socket for CERDIP and PDIP packages;  $\theta_{JA}$  is specified for device soldered to printed circuit board for SOIC package.

Table 5. Thermal Resistance

Package Type	$\theta_{JA}$	$\theta_{JC}$	Unit
14-Pin Ceramic DIP (Y)	94	10	°C/W
14-Pin Plastic DIP (P)	76	33	°C/W
16-Pin SOIC (S)	88	23	°C/W

### ESD CAUTION



**ESD (electrostatic discharge) sensitive device.** Charged devices and circuit boards can discharge without detection. Although this product features patented or proprietary protection circuitry, damage may occur on devices subjected to high energy ESD. Therefore, proper ESD precautions should be taken to avoid performance degradation or loss of functionality.

TYPICAL PERFORMANCE CHARACTERISTICS

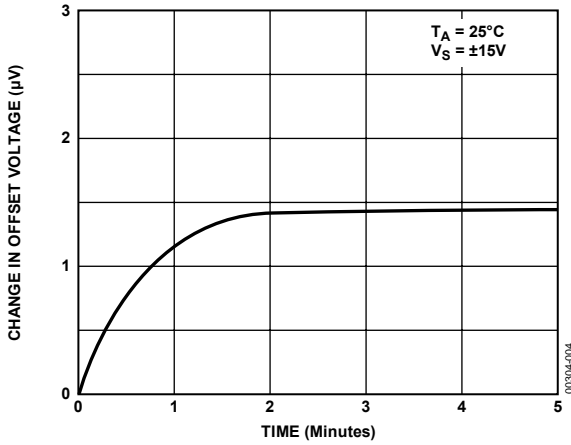

Figure 4. Warming Drift

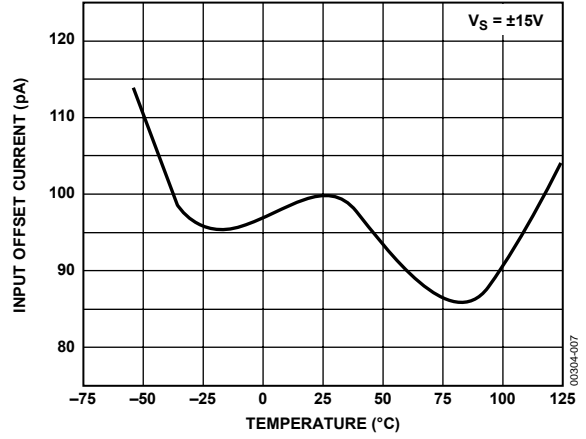

Figure 7. Input Offset Current vs. Temperature

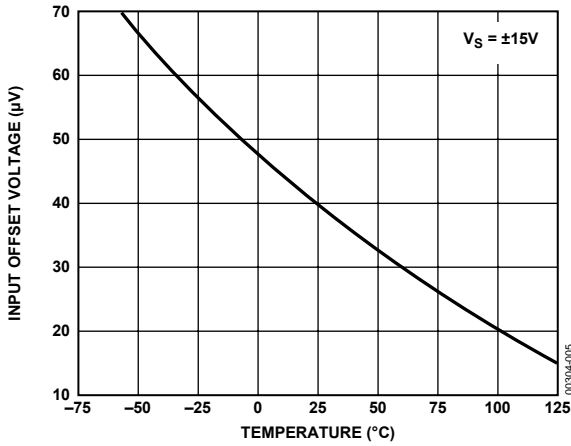

Figure 5. Input Offset Voltage vs. Temperature

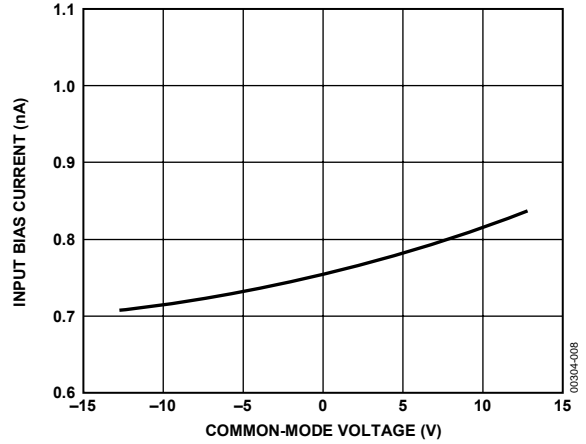

Figure 8. Input Bias Current vs. Common-Mode Voltage

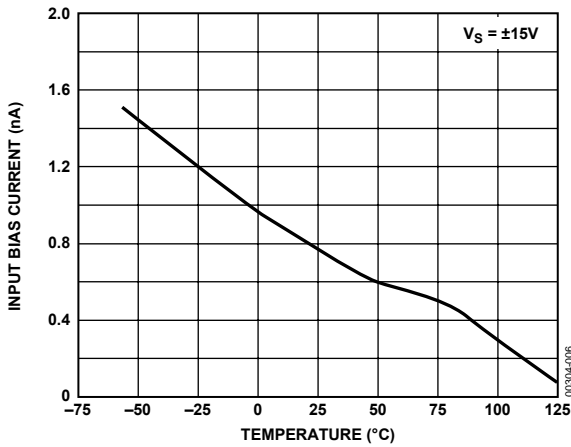

Figure 6. Input Bias Current vs. Temperature

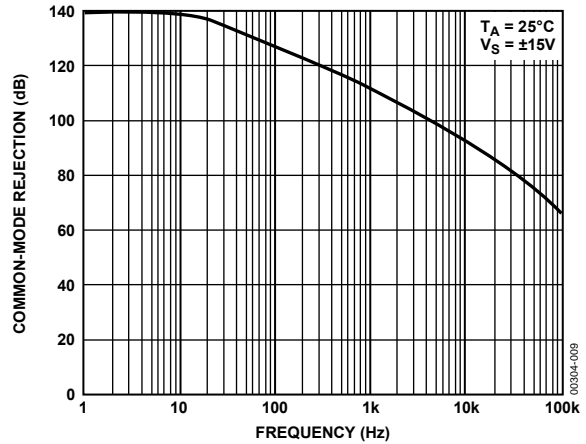

Figure 9. Common-Mode Rejection vs. Frequency

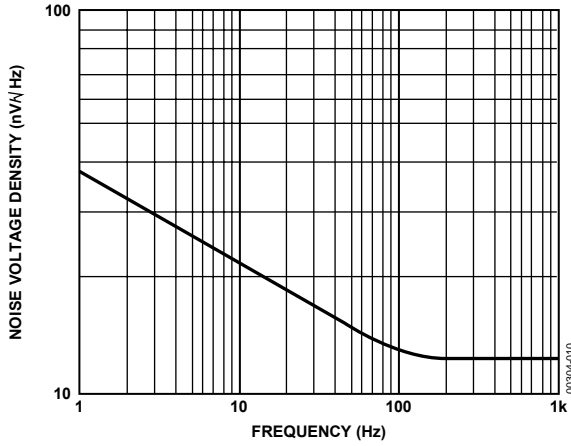

Figure 10. Noise Voltage Density vs. Frequency

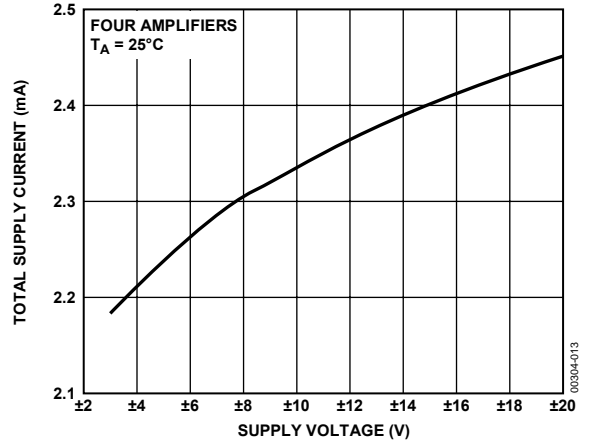

Figure 13. Total Supply Current vs. Supply Voltage

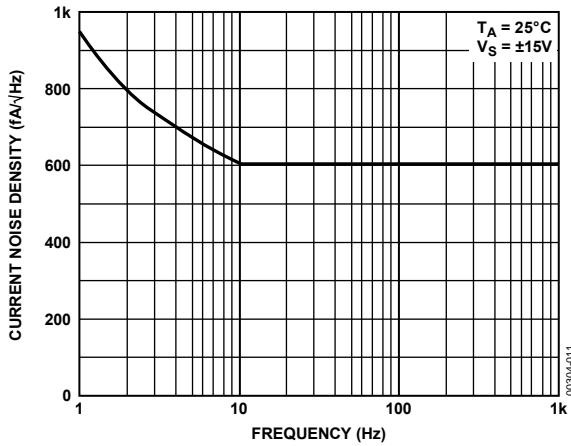

Figure 11. Current Noise Density vs. Frequency

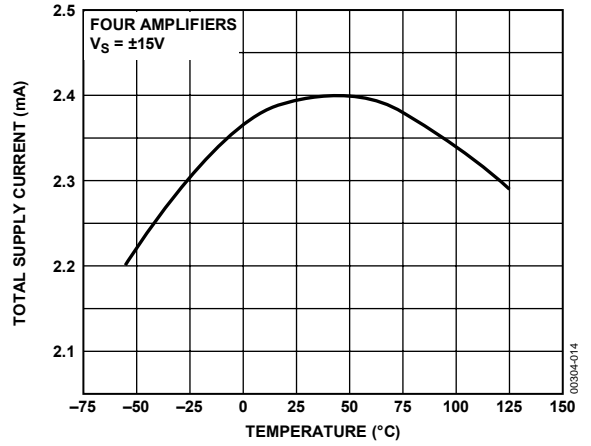

Figure 14. Total Supply Current vs. Temperature

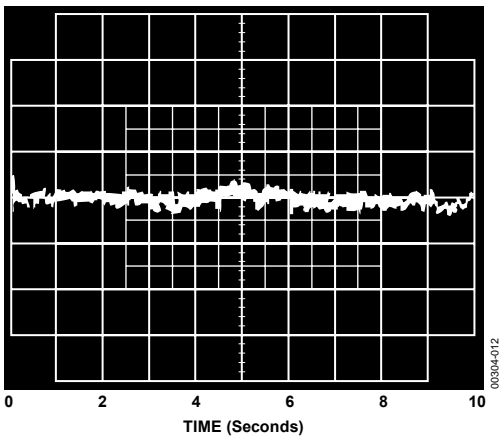

Figure 12. 0.1 Hz to 10 Hz Noise

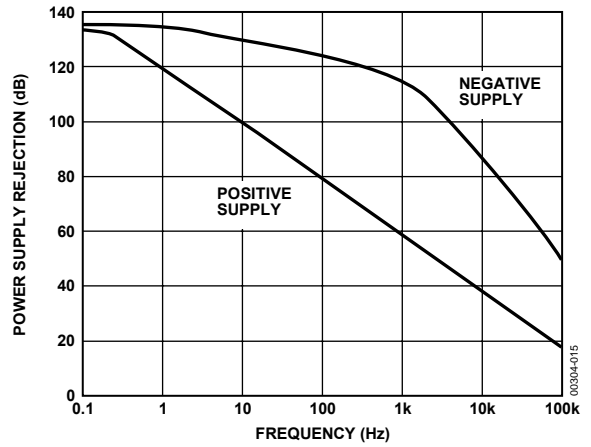

Figure 15. Power Supply Rejection vs. Frequency

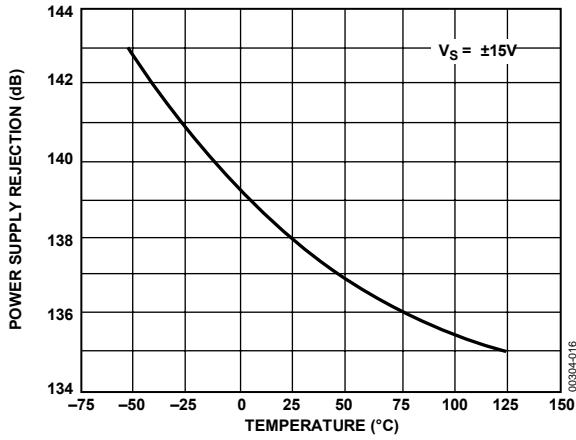

Figure 16. Power Supply Rejection vs. Temperature

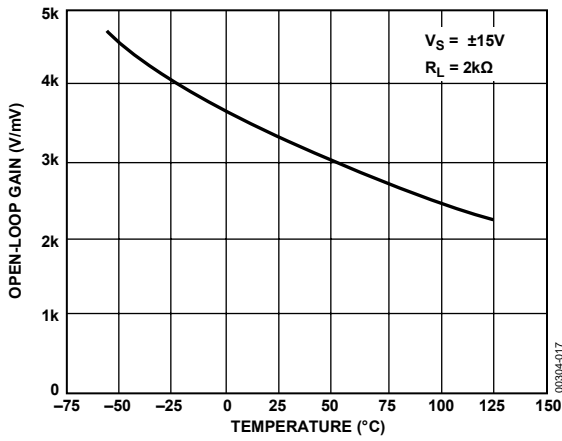

Figure 17. Open-Loop Gain vs. Temperature

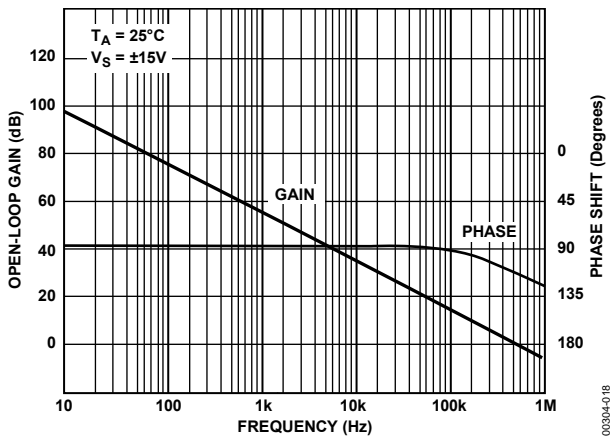

Figure 18. Open-Loop Gain and Phase Shift vs. Frequency

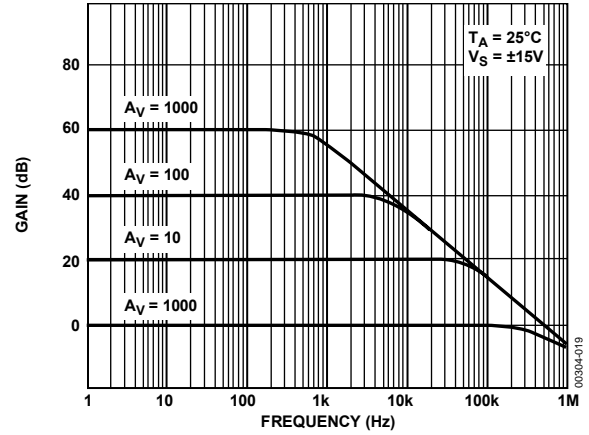

Figure 19. Closed-Loop Gain vs. Frequency

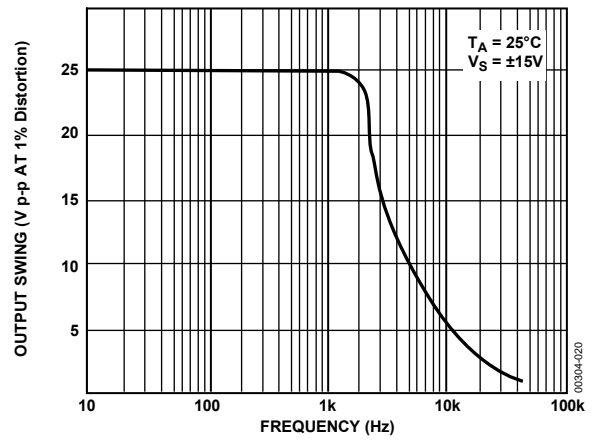

Figure 20. Maximum Output Swing Frequency

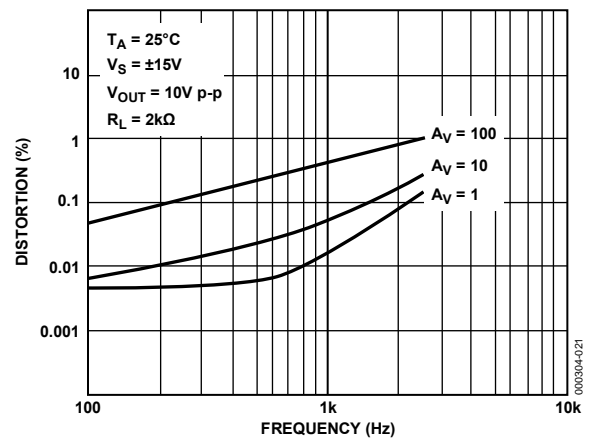

Figure 21. Total Harmonic Distortion vs. Frequency



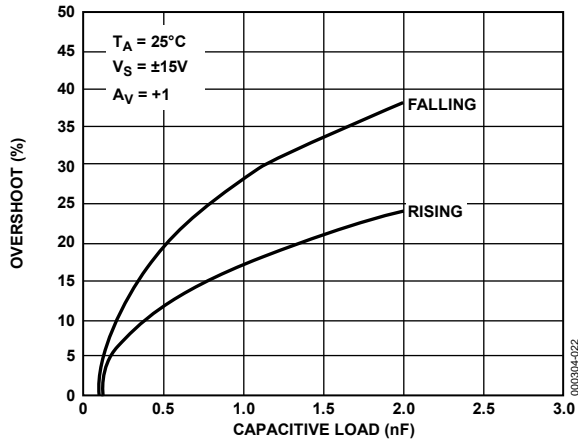

Figure 22. Overshoot vs. Capacitive Load

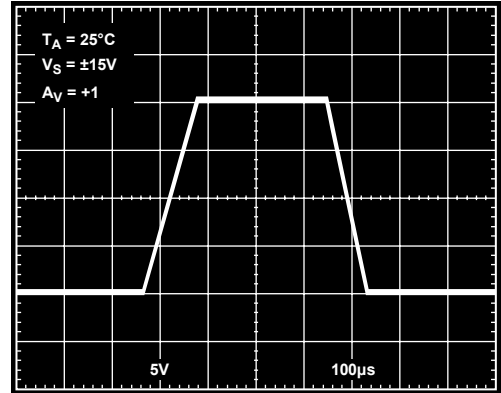

Figure 25. Large Signal Transient Response

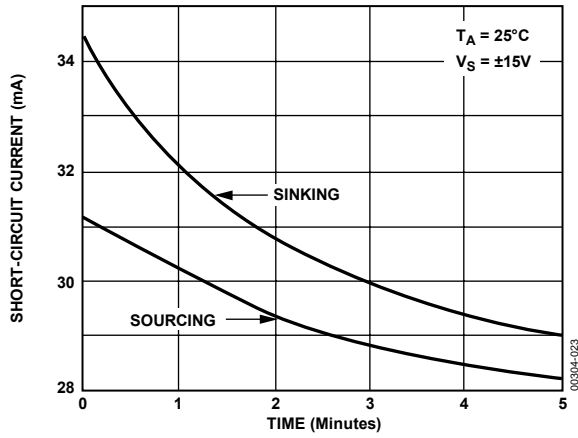

Figure 23. Short Circuit vs. Time

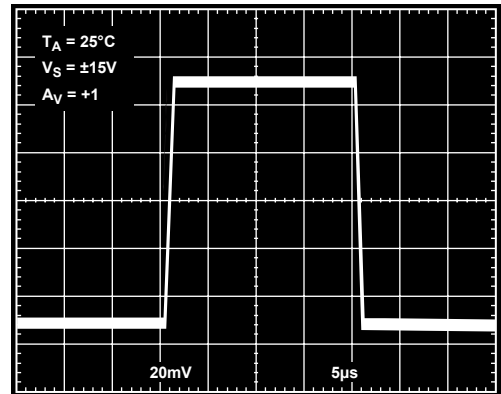

Figure 26. Small Signal Transient Response

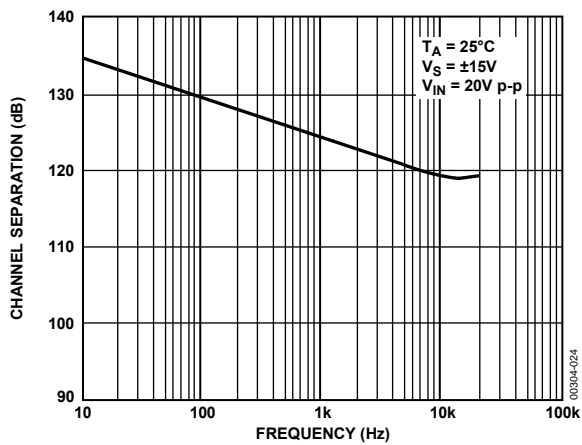

Figure 24. Channel Separation vs. Frequency

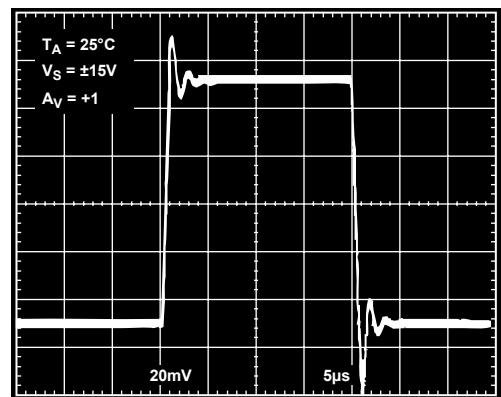

Figure 27. Small Signal Transient Response,  $C_{LOAD} = 1\text{ nF}$

# OP400

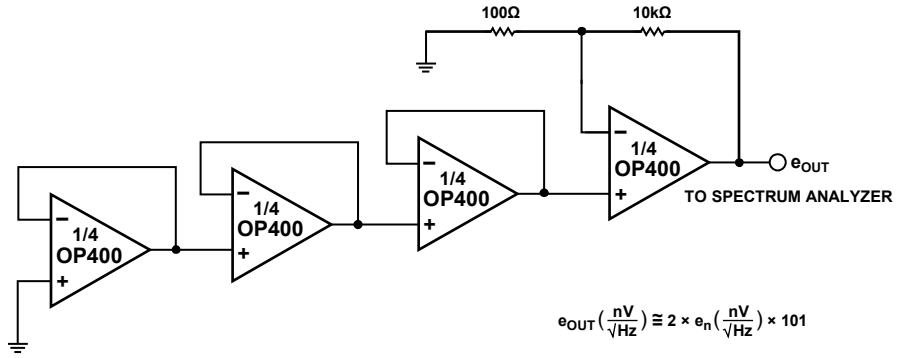

Figure 28. Noise Test Schematic

00304-028

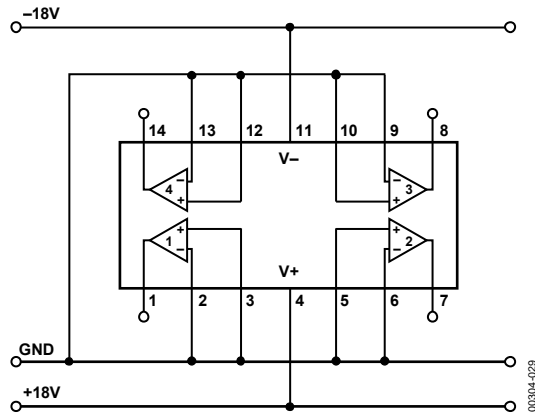

Figure 29. Burn-In Circuit

00304-029

## APPLICATIONS

The OP400 is inherently stable at all gains and is capable of driving large capacitive loads without oscillating. Nonetheless, good supply decoupling is highly recommended. Proper supply decoupling reduces problems caused by supply line noise and improves the capacitive load-driving capability of the OP400.

Total supply current can be reduced by connecting the inputs of an unused amplifier to V-. This turns the amplifier off, lowering the total supply current.

### DUAL LOW POWER INSTRUMENTATION AMPLIFIER

A dual instrumentation amplifier that consumes less than 33 mW of power per channel is shown in Figure 30. The linearity of the instrumentation amplifier exceeds 16 bits in gains of 5 to 200 and is better than 14 bits in gains from 200 to 1000. CMRR is above 115 dB (G = 1000). Offset voltage drift is typically 0.4 μV/°C over the military temperature range, which is comparable to the best monolithic instrumentation amplifiers. The bandwidth of the low power instrumentation amplifier is a function of gain and is shown in Table 6.

The output signal is specified with respect to the reference input, which is normally connected to analog ground. The reference input can be used to offset the output from -10 V to +10 V if required.

Table 6. Gain Bandwidth

Gain	Bandwidth
5	150 kHz
10	67 kHz
100	7.5 kHz
1000	500 Hz

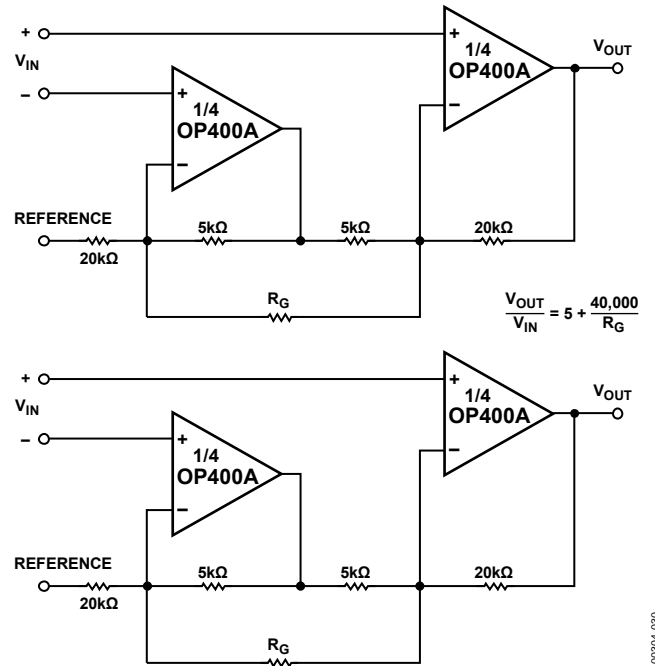

Figure 30. Dual Low Power Instrumentation Amplifier

00304-030

## BIPOLAR CURRENT TRANSMITTER

In the circuit of Figure 31, which is an extension of the standard three op amp instrumentation amplifier, the output current is proportional to the differential input voltage. Maximum output current is  $\pm 5$  mA, with voltage compliance equal to  $\pm 10$  V when using  $\pm 15$  V supplies. Output impedance of the current transmitter exceeds  $3 \text{ M}\Omega$ , and linearity is better than 16 bits with gain set for a full-scale input of  $\pm 100 \mu\text{V}$ .

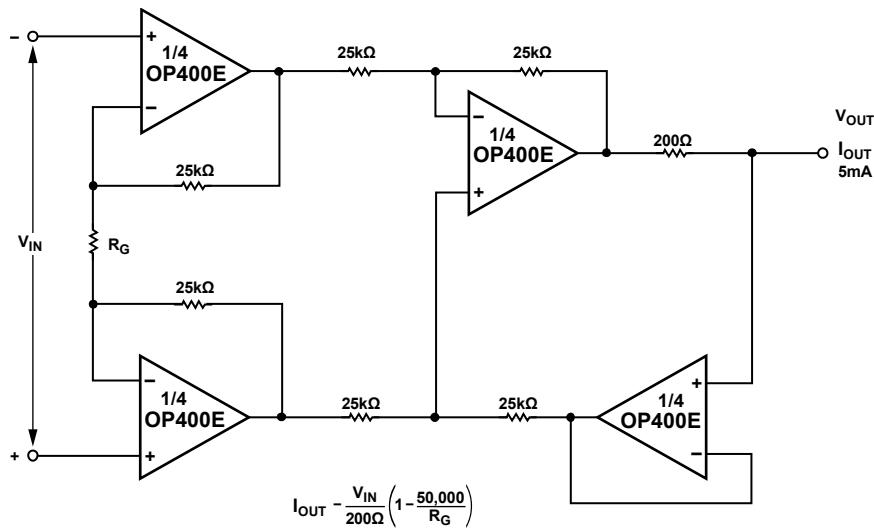

Figure 31. Bipolar Current Transmitter

00304-031

## DIFFERENTIAL OUTPUT INSTRUMENTATION AMPLIFIER

The output voltage swing of a single-ended instrumentation amplifier is limited by the supplies, normally at  $\pm 15$  V, to a maximum of 24 V p-p. The differential output instrumentation amplifier shown in Figure 32 can provide an output voltage swing of 48 V p-p when operated with  $\pm 15$  V supplies. The extended output swing is due to the opposite polarity of the outputs. Both outputs swing 24 V p-p, but with opposite polarity, for a total output voltage swing of 48 V p-p. The reference input can be used to set a common-mode output voltage over the range  $\pm 10$  V. The PSRR of the amplifier is less than  $1 \mu\text{V}/\text{V}$  with CMRR ( $G = 1000$ ) better than 115 dB. Offset voltage drift is typically  $0.4 \mu\text{V}/^\circ\text{C}$  over the military temperature range.

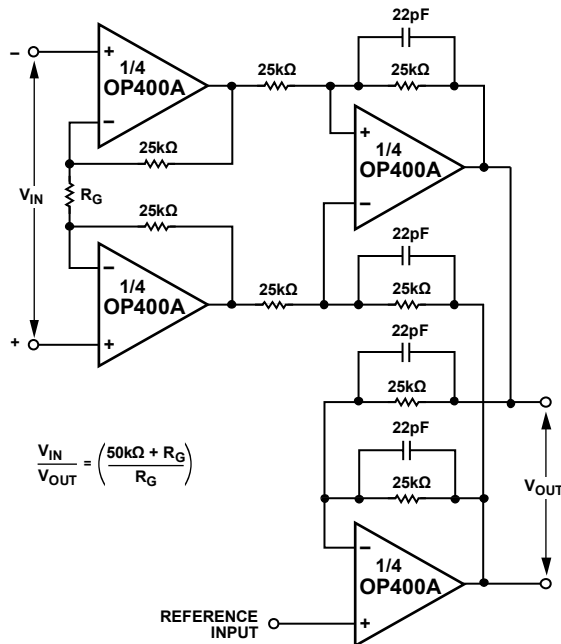

Figure 32. Differential Output Instrumentation Amplifier

00304-032

**MULTIPLE OUTPUT TRACKING VOLTAGE REFERENCE**

Figure 33 shows a circuit that provides outputs of 10 V, 7.5 V, 5 V, and 2.5 V for use as a system voltage reference. Maximum output current from each reference is 5 mA with load regulation

under 25  $\mu\text{V}/\text{mA}$ . Line regulation is better than 15  $\mu\text{V}/\text{V}$ , and output voltage drift is under 20  $\mu\text{V}/^\circ\text{C}$ . Output voltage noise from 0.1 Hz to 10 Hz is typically 75  $\mu\text{V}$  p-p from the 10 V output and proportionately less from the 7.5 V, 5 V, and 2.5 V outputs.

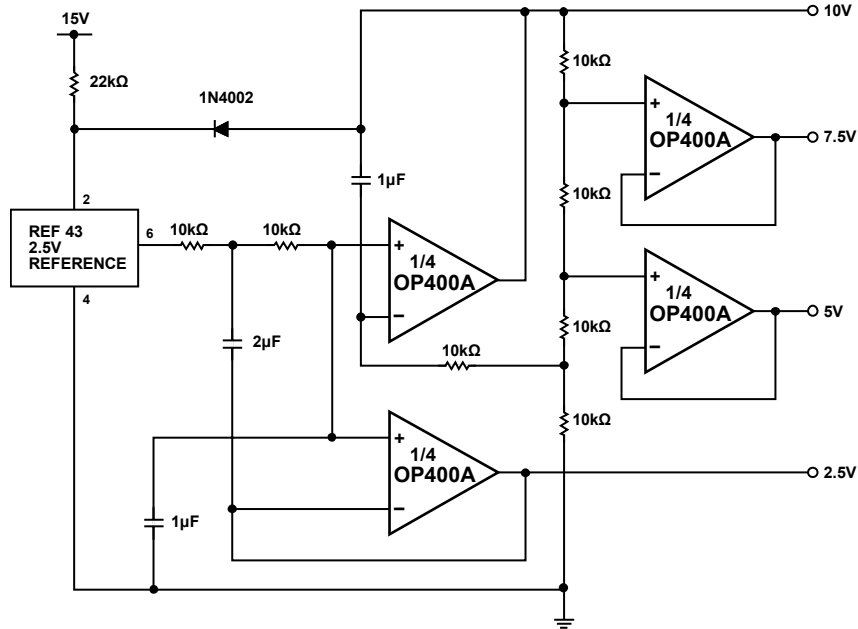
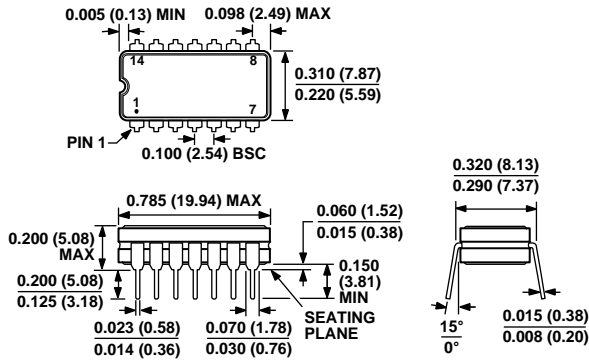

Figure 33. Multiple Output Tracking Voltage Reference

00304-033

# OP400

## OUTLINE DIMENSIONS



CONTROLLING DIMENSIONS ARE IN INCHES; MILLIMETER DIMENSIONS (IN PARENTHESES) ARE ROUNDED-OFF INCH EQUIVALENTS FOR REFERENCE ONLY AND ARE NOT APPROPRIATE FOR USE IN DESIGN.

Figure 34. 14-Lead Ceramic Dual In-Line Package [CERDIP]  
(Q-14)  
[Y-Suffix]  
Dimensions shown in inches and (millimeters)

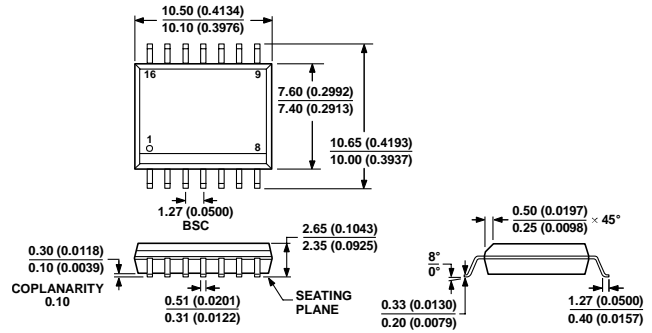

COMPLIANT TO JEDEC STANDARDS MS-013-AA  
CONTROLLING DIMENSIONS ARE IN MILLIMETERS; INCH DIMENSIONS (IN PARENTHESES) ARE ROUNDED-OFF MILLIMETER EQUIVALENTS FOR REFERENCE ONLY AND ARE NOT APPROPRIATE FOR USE IN DESIGN.

Figure 36. 16-Lead Standard Small Outline Package [SOIC\_W]  
Wide Body (R-16)  
[S-Suffix]  
Dimensions shown in millimeters and (inches)

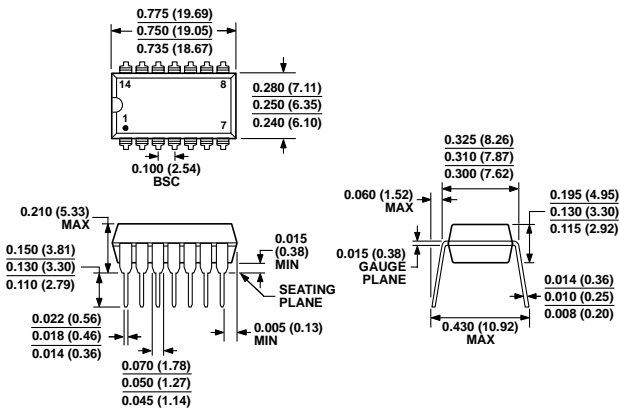

COMPLIANT TO JEDEC STANDARDS MS-001  
CONTROLLING DIMENSIONS ARE IN INCHES; MILLIMETER DIMENSIONS (IN PARENTHESES) ARE ROUNDED-OFF INCH EQUIVALENTS FOR REFERENCE ONLY AND ARE NOT APPROPRIATE FOR USE IN DESIGN. CORNER LEADS MAY BE CONFIGURED AS WHOLE OR HALF LEADS.

Figure 35. 14-Lead Plastic Dual In-Line Package [PDIP]  
(N-14)  
[P-Suffix]  
Dimensions shown in inches and (millimeters)

**ORDERING GUIDE**

Model	Temperature Range	Package Description	Package Option
OP400AY	-55°C to +125°C	14-Lead CERDIP	Y-Suffix (Q-14)
OP400EY	-25°C to +85°C	14-Lead CERDIP	Y-Suffix (Q-14)
OP400FY	-25°C to +85°C	14-Lead CERDIP	Y-Suffix (Q-14)
OP400GP	0°C to +70°C	14-Lead PDIP	P-Suffix (N-14)
OP400GPZ <sup>1</sup>	0°C to +70°C	14-Lead PDIP	P-Suffix (N-14)
OP400HP	-40°C to +85°C	14-Lead PDIP	P-Suffix (N-14)
OP400HPZ <sup>1</sup>	-40°C to +85°C	14-Lead PDIP	P-Suffix (N-14)
OP400GS	0°C to +70°C	16-Lead SOIC_W	S-Suffix (RW-16)
OP400GS-REEL	0°C to +70°C	16-Lead SOIC_W	S-Suffix (RW-16)
OP400GSZ <sup>1</sup>	0°C to +70°C	16-Lead SOIC_W	S-Suffix (RW-16)
OP400GSZ-REEL <sup>1</sup>	0°C to +70°C	16-Lead SOIC_W	S-Suffix (RW-16)
OP400HS	-40°C to +85°C	16-Lead SOIC_W	S-Suffix (RW-16)
OP400HS-REEL	-40°C to +85°C	16-Lead SOIC_W	S-Suffix (RW-16)
OP400HSZ <sup>1</sup>	-40°C to +85°C	16-Lead SOIC_W	S-Suffix (RW-16)
OP400HSZ-REEL <sup>1</sup>	-40°C to +85°C	16-Lead SOIC_W	S-Suffix (RW-16)
OP400GBC		Die	

<sup>1</sup> Z = Pb-free part.

**SMD PARTS AND EQUIVALENTS**

SMD Part Number <sup>1</sup>	Analog Devices Equivalent
5962-8777101M3A	OP400ATCMDA
5962-8777101MCA	OP400AYMDA

<sup>1</sup> For military processed devices, please refer to the standard microcircuit drawing (SMD) available at the Defense Supply Center Columbus website.

**OP400**

**NOTES**